



**TRUE FOOD SERVICE
EQUIPMENT, INC.**

2001 East Terra Lane • P.O. Box 970 • O'Fallon, Missouri 63366
(636)240-2400 • Fax (636)272-2408 • (800)325-6152 • Intl Fax# (001)636-272-7546
Parts Dept. (800)424-TRUE • Parts Dept. Fax# (636)272-9471 • www.truefmfg.com

Project Name: _____

Location: _____

Item #: _____ Qty: _____

Model #: _____

A/A #

S/S #

Model:
T-49DT-G

T-Series:

Reach-In Glass Swing Door Dual Temperature Refrigerator/Freezer



T-49DT-G

- ▶ Designed using the highest quality materials and components to provide the user with colder product temperatures, lower utility costs, exceptional food safety and the best value in today's food service marketplace.
- ▶ Refrigerator located in left section; freezer in the right.
- ▶ Equipped with two, self-contained, independent refrigeration systems. Oversized and factory balanced; refrigerator section holds 33°F to 38°F (.5°C to 3.3°C); freezer holds -10°F (-23.3°C).
- ▶ Energy efficient, "Low-E", double pane thermal tempered glass doors in refrigerator section.
- ▶ Energy efficient, triple pane thermal insulated glass door(s) in freezer section.
- ▶ Adjustable, heavy duty PVC coated shelves.
- ▶ Positive seal self-closing doors. Lifetime guaranteed door hinges and torsion type closure system.

Bottom mounted units feature:

- ▶ "No stoop" lower shelf.
- ▶ Storage on top of cabinet.
- ▶ Compressors perform in coolest, most grease free area of kitchen.
- ▶ Easily accessible condenser coil for cleaning.

ROUGH-IN DATA

Specifications subject to change without notice.
Chart dimensions rounded up to the nearest 1/8" (millimeters rounded up to next whole number).

Model	Doors	Capacity (Cu. Ft.) (liters)		Shelves	Cabinet Dimensions (inches) (mm)			HP		Voltage	Amps	NEMA Config.	Cord Length (total ft.) (total m)	Crated Weight (lbs.) (kg)
		Ref.	Frz.		L	D†	H*	Ref.	Frz.					
T-49DT-G	2	23 652	23 652	6	54½ 1375	29¾ 756	78¾ 1991	½	¾	115/208-230/60	14.2	14-20P	9 2.74	570 259

* Height does not include 5" (127 mm) for castors or 6" (153 mm) for optional legs.
† Depth does not include 1 3/8" (35 mm) for door handles.
Requires 115/208-230/60 Hz, single phase, 3 pole, 4 wire circuit.

	<p>APPROVALS:</p>	<p>AVAILABLE AT:</p>
<p>Printed in U.S.A.</p>		

Model:
T-49DT-G

T-Series:
Reach-In Glass Swing Door Dual Temperature Refrigerator/Freezer



STANDARD FEATURES

DESIGN

- True's glass door reach-in's are designed with enduring quality that protects your long term investment.
- True's commitment to using the highest quality materials and oversized refrigeration systems provides the user with colder product temperatures, lower utility costs, exceptional food safety and the best value in today's food service marketplace.

REFRIGERATION SYSTEM

- Equipped with two, independent, factory engineered, self-contained, capillary tube refrigeration systems using environmentally friendly (CFC free) refrigerant. Refrigerator uses 134A and freezer uses R404A.
- Refrigerator located in left section; freezer in the right.
- Extra large evaporator coils balanced with higher horsepower compressors and large condensers; maintain colder standard temperatures for the best in food preservation. Refrigerator holds 33°F to 38°F (.5°C to 3.3°C); freezers holds -10°F (-23.3°C).
- Sealed, cast iron, self-lubricating evaporator fan motors and larger fan blades give True reach-in's a more efficient, low velocity, high volume airflow design. This unique design ensures faster temperature recovery and shorter run times in the busiest of food service environments.
- Bottom mounted condensing units positioned for easy cleaning. Compressors run in coolest and most grease free area of the kitchen. Allows for storage area on top of unit.
- Automatic freezer defrost system time-initiated, temperature-terminated. Saves energy consumption and provides shortest possible defrost cycle.

CABINET CONSTRUCTION

- Exterior - Stainless steel front. Anodized quality aluminum ends, back and top.
- Interior - attractive, NSF approved, white aluminum liner. 300 series stainless floor with coved corners.
- Insulation - entire cabinet structure is foamed-in-place using Ecomate. A new, innovative, high density, polyurethane insulation that has zero ozone depletion potential (ODP) and zero global warming potential (GWP).

- Welded, heavy duty steel frame rail, black powder coated for corrosion protection.
- Frame rail fitted with 4" (102 mm) diameter stem castors - locks provided on front set.

DOORS

- "Low-E", double pane thermal glass assembly in refrigerator door(s). Triple pane thermal glass assembly in freezer door(s).
- Extruded aluminum frame(s). Door lock(s) standard.
- Each door fitted with 15" (381 mm) long extruded aluminum handle.
- Positive seal self-closing doors. Lifetime guaranteed door hinges and torsion type closure system.
- Magnetic door gaskets of one piece construction, removable without tools for ease of cleaning.

SHELVING

- Six (6) adjustable, heavy duty PVC coated wire shelves 22 7/8" L x 23 1/4" D (582 mm x 591 mm). Four (4) chrome plated shelf clips included per shelf.
- Shelf support pilasters made of same material as cabinet interior; shelves are adjustable on 1/2" (13 mm) increments.

LIGHTING

- Compartmentalized, fluorescent interior lighting (one per section). Each door utilizes full-length, patented, integrated door light (IDL) system. Safety shielded.

MODEL FEATURES

- Two (2) exterior mounted digital temperature displays, one for refrigerator section and one for freezer.
- Evaporator is epoxy coated to eliminate the potential of corrosion.
- Rear airflow guards prevent product from blocking optimal airflow.
- Minimum wattage heater in cabinet frame and freezer door.
- NSF-7 compliant for open food product.

ELECTRICAL

- Unit completely pre-wired at factory and ready for final connection to a 115/208-230/60Hz single phase, 3 pole, 4 wire, 20 amp dedicated outlet. Cord and plug set included.



115/208-230/1
NEMA-14-20R

OPTIONAL FEATURES/ACCESSORIES

Upcharge and lead times may apply.

- 6" (153 mm) standard legs.
- 6" (153 mm) seismic/flanged legs.
- Additional shelves.
- Novelty baskets.
- Half door bun tray racks. Each holds up to eleven 18"L x 26"D (458 mm x 661 mm) sheet pans (sold separately) (airflow guard needs to be removed from freezer).
- Full door bun tray racks. Each holds up to twenty-two 18"L x 26"D (458 mm x 661 mm) sheet pans (sold separately) (airflow guard needs to be removed from freezer).
- Remote cabinets (condensing unit supplied by others; system comes standard with 404A expansion valve and requires R404A refrigerant). Consult factory technical service department for BTU information. All remote units must be hard wired during installation.

PLAN VIEW

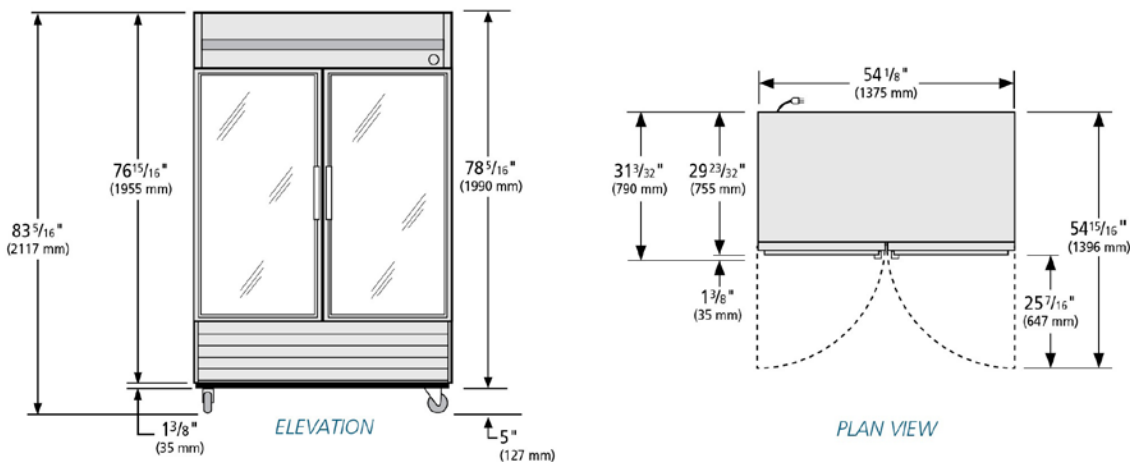

WARRANTY
One year warranty on all parts and labor and an additional 4 year warranty on compressor. (U.S.A. only)

METRIC DIMENSIONS ROUNDED UP TO THE NEAREST WHOLE MILLIMETER
SPECIFICATIONS SUBJECT TO CHANGE WITHOUT NOTICE



Model	Elevation	Right	Plan	3D	Back
T-49DT-G	TFEY67E	TFEY06S	TFEY07P	TFEY673	

TRUE FOOD SERVICE EQUIPMENT